



IEAESP2018-209

Project Title: SMART RIFLE FOR MILITARY MONITORING SYSTEM

Guide Details

Guide Name: C.Silpa

Guide Email: silpa.c8@gmail.com

Guide Phone NO.: 919440861417

Qualification : M.Tech.

Department: Information Technology

Institute name : Sree Vidyanikethan Engineering College

College address : Rangampet, Chandragiri

Students Details

Project Team Leader Name: K R Manju Bhargavi

Email: manjubhargavi28@gmail.com

Phone No. : 7396232306

Team Members list : G.Aparna, K.Lalith Kumar, J.Sunil



TITLE: SMART RIFLE FOR MILITARY MONITORING SYSTEM

ABSTRACT

In today's world, face recognition is an important part for the purpose of security and surveillance. Facial recognition is a well-established process in which the face is detected and identified out of the image. This face recognition technology can be used in military for effective monitoring. The proposed system deals with the idea of smart rifle using IoT(Internet of Things) and face recognition technology for military monitoring to provide high security. It uses an image capturing technique in an embedded system based on Raspberry Pi. Raspberry Pi is used to control the video camera and turn on a motor for firing. The camera rotates, then catches the facial picture of a person and compares it with the image which is stored in the database. If the picture is not found in the database, he/she is considered as an un-authenticated person, then the smart rifle is triggered and the information is sent to a security official through an e-mail service.

Keywords : Internet of Things, Open cv, Raspberry Pi.



INTRODUCTION

Face detection is the most popular area of research in the vision of computer science. It is a computer technology which is being used in a various applications that identifies human faces in digital images. The research under this field is expanding in many areas of science such as psychology. Localization of human faces is considered as the primary and the initial stage in study of face detection. For example in home video surveillance etc. Face localization can be referred to as extraction of facial features using pattern recognition system. OpenCV can be used for creating such prototypes and systems. In this paper, research has been carried out using OpenCV to provide security at borders.

LITERATURE SURVEY

In [1] Imagine a world in which every device in the home, workplace and car are connected. A world where the lights automatically turn on when the car approaches the driveway, the coffee starts brewing when the morning alarm goes off and the front door automatically opens when a authenticated person is approached, but stays locked when a un-authenticated is approached. That is the type of world the Internet of Things can create.

In [5] an intelligent system for home security using illumination sensitive background model is presented. Such system enables tracking and detection of intruder and it is based on providing home security. For this purpose, a face recognition technique is utilized to identify the intruder and on finding him, an image of the intruder is sent on the owner mail id for further action. The implementation of this system also includes the comparison of different approaches for object tracking and then used an illumination-sensitive background modeling approach for the proposed security system.

In [2] Monitoring systems serves as a deterrent to violent crime, we focus on child monitoring turn on when the car approaches the driveway, the coffee starts brewing when the morning alarm goes off and the front door automatically opens when a authenticated person is approached, but stays locked when a un-authenticated is approached. That is the type of world the Internet of Things can create.

In [5] an intelligent system for home security using illumination sensitive background model is presented. Such system enables tracking and detection of intruder and it is based on providing home security. For this purpose, a face recognition technique is utilized to identify the intruder and on finding him, an image of the intruder is sent on the owner mail id for further action. The implementation of this system also includes the comparison of different approaches for object tracking and then used an illumination-sensitive background modeling approach for the proposed security system.system using motion and authentication with Raspberry Pi. We use Raspberry Pi microcomputer with evolutionary prototype method in order to monitor the children with video streaming media and motion detection. Moreover, this prototype can help



parents to monitor children which can be accessed easily by online through the website with authentication feature.

In [3] Face recognition technology emulates the capabilities of human eyes to detect faces. This is done by smart computing that creates “face bunch” that consists of 70 nodal points. Features are extracted from the face and saved as templates. These templates are compared to the face detected.

DESIGN, METHODOLOGY, IMPLEMENTATION

PROPOSED METHOD

BLOCK DIAGRAM

1. **Raspberry pi:** The Raspberry Pi is a credit card size computer which is a 900MHz quad-core ARM Cortex-A7 CPU. It has a 1GB RAM and an additional memory is provided by using a micro SD card. It has 4 USB ports, 40 GPIO pins. A Full HDMI port is used to connect to a display.
2. **Logitech web-cam:** Webcams are small digital video cameras that hook up to your computer at the USB. Web cam is interfaced to the Raspberry Pi module. It is used to capture images and send the clicked images to the raspberry pi module.
3. **Mouse and KeyBoard:** Mouse and Keyboard are used to pass commands to the Raspberry Pi.
4. **Database:** Database stores images containing features of authenticated users. It used to compare the images captured by web-cam against the images stored in database to differentiate authenticated users from those of un- authenticated ones.
5. **DC Motor:** DC motors convert electrical energy into mechanical energy. DC motors are made of permanent magnets and loops of wire. A DC Motor is a fairly simple electric motor that produces torque by using uses electricity field and magnetic field, which turns the motor and gives mechanical work. Here, DC motor is used to rotate the system.
6. **DC Motor Driver:** L293D is a dual H-bridge motor driver integrated circuit (IC). Motor drivers act as current amplifiers since they take a low-current control signal and provide a higher-current signal. This higher current signal is used to drive the motors. In its common mode of operation, two DC motors can be driven simultaneously, both in forward and reverse direction.
7. **Relay:** Relays are suitable for driving high power electric equipment, such as light bulbs, electric fans and air conditioning. You can use a relay to control high voltage with low voltage by connecting it to Raspberry Pi. Here, relay is used to control the gun.
8. **Gun:** Gun is triggered with the help of relay. Gun is used to target an un-authenticated user who is not recognized in the database.

2) Fig. 1. Block diagram of the system.

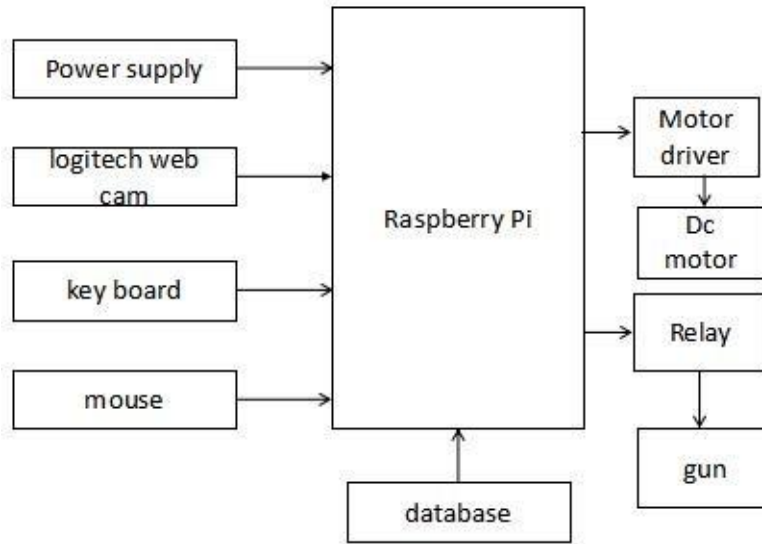

Fig. : Block diagram of the system.

SOFTWARE

- 1) **Raspbian OS:** A Raspbian is a free operating system optimized for the Raspberry Pi hardware. Image files are copied differently in Windows, compared to Linux and Mac computers. In both systems, firstly format the micro SD card, then download the operating system as an image file. This file is then copied bit by bit as an exact replica to the micro SD card.
- 2) **OpenCV:** Open Source Computer Vision Library) uses c/c++ library functions. It directly provides the computer with the machine language code and helps in faster execution. It consists of 2500 optimized algorithms. Using OpenCV results in effective utilization of time and resources in image- processing.

WORKING PRINCIPLE

The overall working of this system can be explained with the help of flow diagram. Firstly, the logitech webcam captures the images of user, human faces if any are detected in those images. Once, the human face is detected it is compared with the ones that are stored in the database. If the detected face is not recognized in database, gun is triggered and notification is sent to the security controller.

Human Face Detection

Generally, the method of identifying the presence of objects of specific class is referred to as object detection. This can be extended as a method of image processing to identify objects from digital images.

Fig: Flow diagram of the military monitoring system.

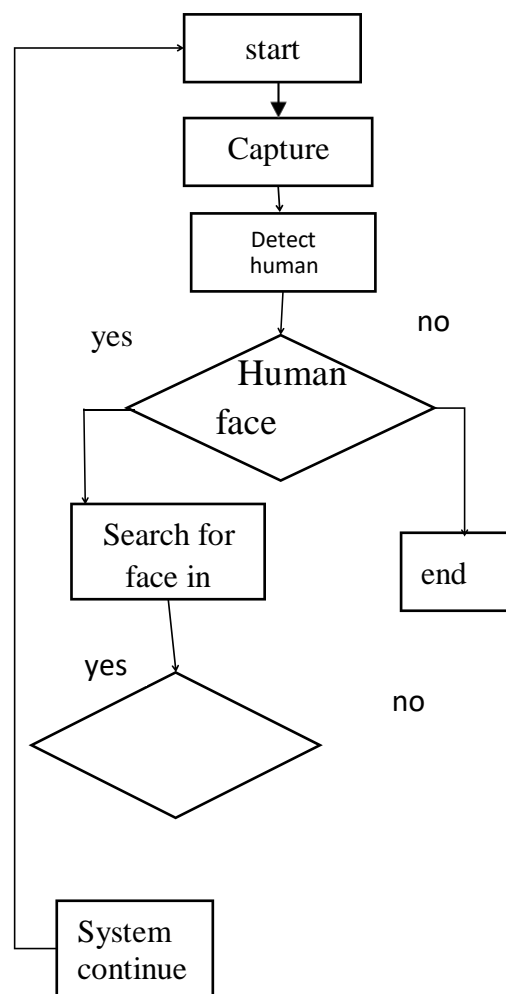

Haar-like Features: Neighboring rectangular regions at a specific location in a detection window are considered in haar-like features. It sums up the intensities of pixels in each region and calculates the difference between sums. Subsections of an image are categorized based on this difference.

An example, is detection of human faces. Commonly, the areas on the cheeks are lighter than the areas around the eyes. Two neighboring rectangular areas above the eye and cheek regions that are set is one of the examples of haar-like feature. [4]

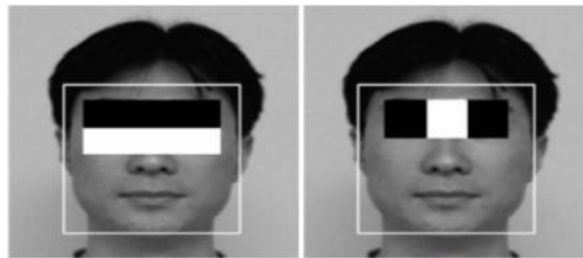

Fig : Haar-like features for face detection

Cascade classifier: There are no of stages in cascade classifier. There are a no of weak learners in every stage of this classifier. A window is moved over an image to find if desired objects are present. The location of window is named as either positive or negative – positive means that desired object was found or negative means that the desired object was not found in the image. If the naming results as negative, then the classification of this desired region is complete and the location of the window is moved to the next specified location for classification. If the naming results as positive, then the window moves of to the next stage of classification. If all the stages, including the last one, yield a positive result, then classifier yields a final verdict of positive, saying that the object is found in the image.

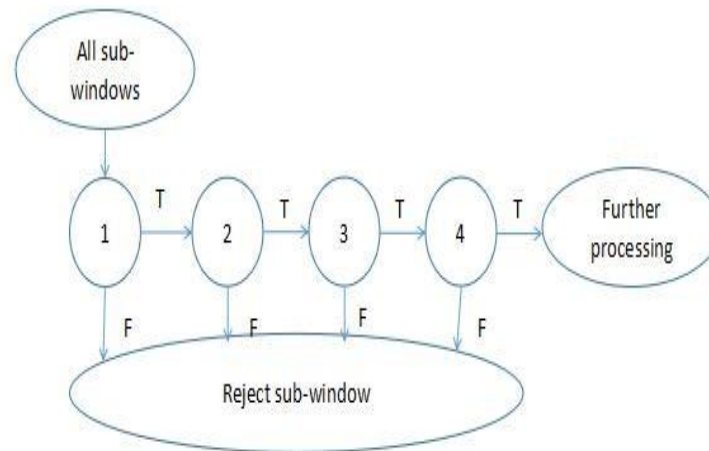

Fig: Stages of cascade classifier.

Background Subtraction: To minimize errors and imperfections of the classifier, layer was added to the algorithm, before the classification. The complete knowledge of background is known to this layer, which can used for filtering of the background from the image from which we would like to detect human face. The background subtraction method used here is frame difference approach.

Frame Difference Approach: It is used to detect moving objects from the difference between the current frame and reference frame.

- Background $B(x,y)$ is estimated.
- Background is substracted from the input frame $I(x,y)$.
- To get the foreground mask,threshold is applied to absolute difference.
- $|Frame\ i - Background\ i| \geq T$

Flow sequence for human face detection: The image is captured from the input video using logitech cam and it is converted into gray scale image. Cascade files of 6++ haar like classifier to detect faces are loaded.

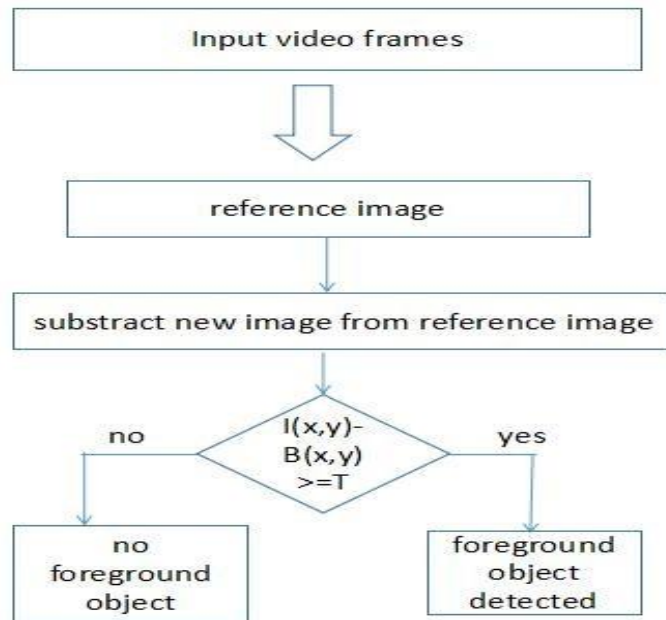

Fig: Flow diagram for background subtraction.

Face Recognition

Recognition is the main part of any security system. Usually for a best recognition system, a well database is required, which can provide the base for our recognition. So to obtain the database, first collect the images of the subject individual for the recognition. Once it is obtained and our system is trained, we can provide face recognition.

Local binary pattern histogram (LBPH) is used for providing face recognition. This method helps us to provide a recognition model. The image is converted into a gray scale image. Then, the image pixels are compared with the neighbouring pixels in a clock-wise or anti-clock manner. Histogram is performed and normalization is done and a feature vector is generated for every image. These feature vectors can now be processed with some algorithms to classify images which is used to identify the texture. Once the face is recognized, it is checked to see if the detected face is familiar or not. Thus, face detection and recognition are integrated to provide a smart military monitoring system.

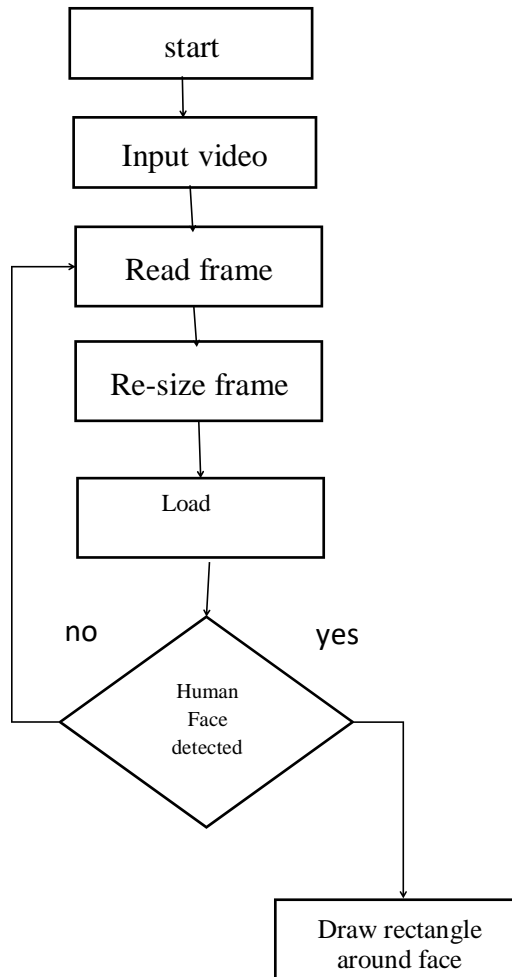

Fig: Flow diagram for face detection

RESULTS

1. System

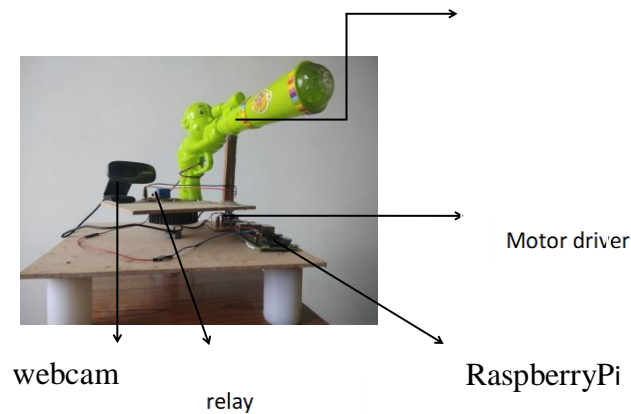

Fig. 8 Smart military monitoring system.

2. Dataset: Images of authenticated person are stored in the database for the purpose of face recognition.

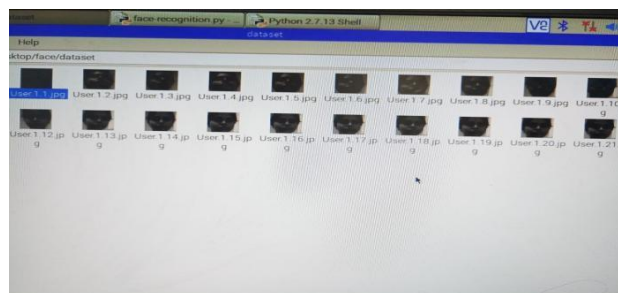

Fig: Images stored in the database

3. Authenticated User: When images of a user is present in the dataset then he/she is considered as authenticated user. In this case, the system detects for the presence of any other human face.

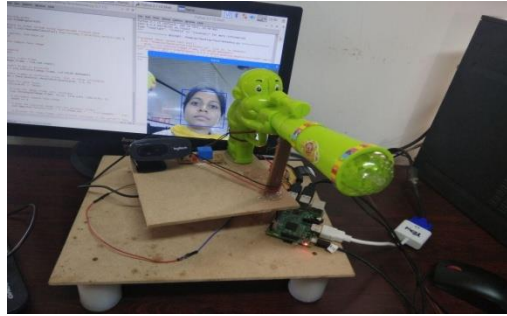

Fig: System in authenticated mode.

4. TrainingSet: Here the system is trained with the images stored in the database.

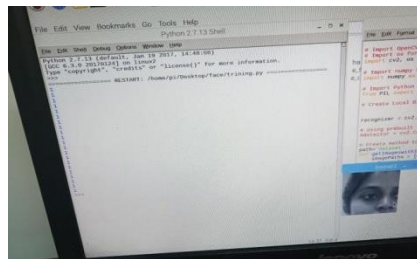

Fig: Training the system

5.Un-Authenticatted User: The relay is in high mode when an user is un-authenticated and now the gun is Triggered. The LED of relay is on only when an user is un-authorized.

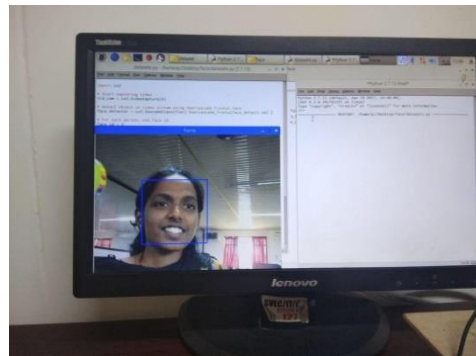

Fig: Un-authenticated user



CONCLUSION

With the development of Science and technology, and rapid growth in the area of internet, trillions of devices are getting connected to internet today, the IoT will surely be promising technology in near future. In this paper, we discuss about the military monitoring system called Smart rifle which can even substitute the participation of human involvement in the borders and can also be used to provide security at the residence of chief authorities, by using this type of devices we can greatly reduce the threat from enemies and efficiency is also increased in the case of monitoring the borders



REFERENCES

1. John A. Stankovic, "Research Directions for the Internet of Things", *Internet of Things Journal*, IEEE, Volume 1, Issue 1, pp.3-9, 2014.
2. Anthony C. Caputo, "Digital Video Surveillance and Security", 2nd ed., USA: Elsevier, Inc., pp. 1-4.
3. W. Zhao, R. Chellappa, P. J. Phillips, A. Rosenfeld, "Face Recognition: A Literature Survey", *ACM Computing Surveys*, Vol. 35, No. 4, December 2003, pp. 399–458.
4. V. Jones, "Rapid object detection using a boosted cascade of simple features," *Computer Vision and Pattern Recognition*, 2001.
5. M. P. V. Kale and S. D. Sharma, "Intelligent Home Security System using illumination sensitive background model," *International Journal of Advance Engineering and Research Development (IJAERD)*, vol. 1, 2014.



5)